

SINTEF confirms that

## Fresvik Panels and Fresvik Elements

has been found to be fit for use in Norway and to meet the provisions regarding product documentation given in the regulation relating to the marketing of products for construction works (DOK) and regulations on technical requirements for building works (TEK), with the properties, fields of application and conditions for use as stated in this document



### 1. Holder of the approval

Fresvik Produkt AS  
 Fresvikvegen 995  
 NO-6896 Fresvik  
[www.fresvik.no](http://www.fresvik.no)

### 2. Product description

#### General

Fresvik Panels and Fresvik Elements are sandwich elements comprising a polyurethane-foam core with a skin of hot-galvanised, cold-rolled steel sheets on either side (see Figs. 1a - c). The sheets are virtually smooth but have longitudinal corrugations. Both types of corrugation on Fresvik Panels and Fresvik Elements are interchangeable (see Figs. 1a - c). The elements are joined together on site by means of moulded-in eccentric locks, or with the help of fastening screws. The elements are attached to the carrying construction with the aid of self-drilling screws.

Standard element width is 1200 mm, although narrower widths can be made to order. Fresvik Panels are available in thicknesses of 75, 100, 125, 150 and 175 mm. Fresvik Elements are available in thicknesses of 100, 125, 150- and 175-mm. Max. available element length is 8.2 m.

#### Fresvik Panel

This type of panel is primarily intended for cold-storage rooms as well as non load-bearing interior partition walls. Fresvik Panels less tongue and groove are usually employed for small and medium-size rooms, whereas panels with tongue and groove are employed in larger projects (see Fig. 2 and Fig. 3).

#### Fresvik Element

This type of element is intended for exterior walls and is fastened to a separate carrying construction. Longitudinal element joints have a tongue and groove as well as a seal (see Fig. 4). Doors, windows, etc., are installed on site.

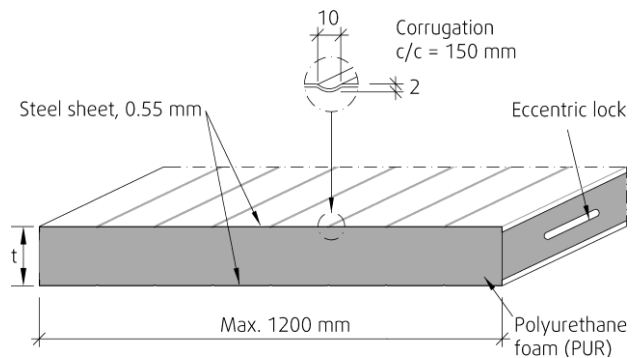

Fig. 1a  
 Fresvik Panel less tongue and groove

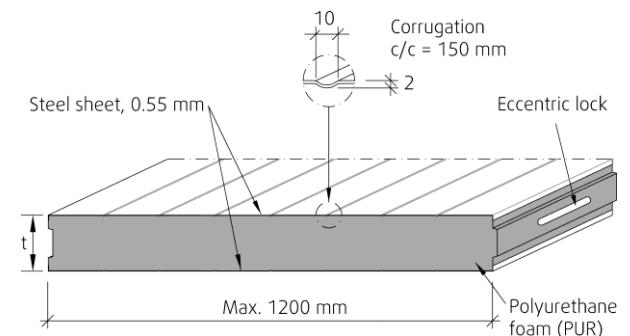

Fig. 1b  
 Fresvik Panel with tongue and groove

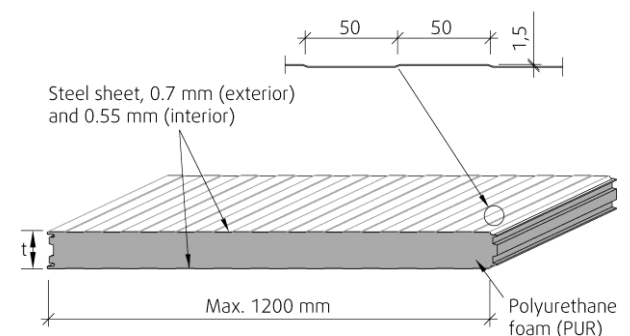

Fig. 1c  
 Fresvik Element

SINTEF is the Norwegian member of European Organisation for Technical Assessment, EOTA, and European Union of Agrément, UEAtc

**Steel sheets**

Steel quality for exterior and interior sheets is S280GD+Z275 in accordance with EN 14783, with tolerances in accordance with EN 10143, EN 505. Standard net sheet-steel thickness is 0.70 mm for exterior sheets and 0.55 mm for interior sheets.

Exterior and interior sheets are hot-galvanised on both sides, with 275 g/m<sup>2</sup> zinc approx. 19 µm, on each side.

Standard surface of Fresvik Panels is 25 µm polyester, type Foodsafe, on both sides. Subject to prior agreement with the customer, paint/lacquer types other than polyester can be applied to the non-visible surfaces.

On Fresvik Elements the standard exterior sheet is coated with 50 µm Pural (alternatively 25 µm PVDF) and the interior sheet with 25 µm polyester. Surfaces of stainless steel or glassboard (plastic) can be supplied to order for particularly harsh/corrosive environments

The sides of the steel sheets adjacent to the foam core are coated with approx. 15 µm epoxy primer.

**Foam core**

Polyurethane foam (PUR), B3, alt. B2, in accordance with DIN 4102, with cyclopentane propellant. Density approx. 40 kg/m<sup>3</sup>.

**Floorboards**

Fresvik Panels can also be used as flooring in cold-storage rooms. The upper steel sheet must then be replaced by (min.) 12 mm thick plywood boards.

**Construction details**

Full details of the elements, appurtenant joining details and the principles for attachment to other building components, are given in "Standard Construction Details for Fresvik Panels and Fresvik Elements pertaining to SINTEF Technical Approval TG 2135". The version that is held by SINTEF Byggforsk at any one time is deemed to be an integral part of the approval.

**3. Fields of application**

Fresvik Panels and Fresvik Elements can be used in industrial buildings and warehouses in Fire Class 1 and for cold-storage rooms in Fire Risk Class 4.

Elements with a Foodsafe surface coating are intended for use in food-production premises and have a surface that facilitates cleaning and prevents bacterial growth.

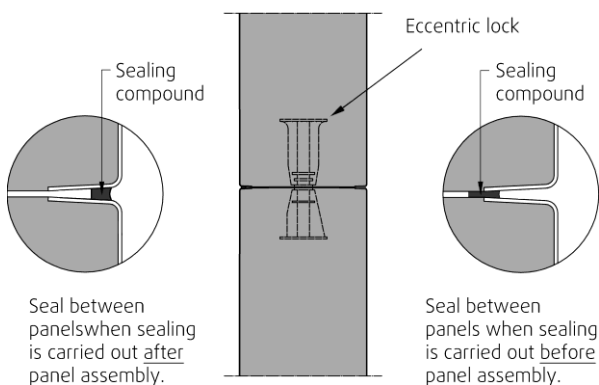

Fig. 2  
Fresvik Panel, less tongue and groove, showing panel joint in detail

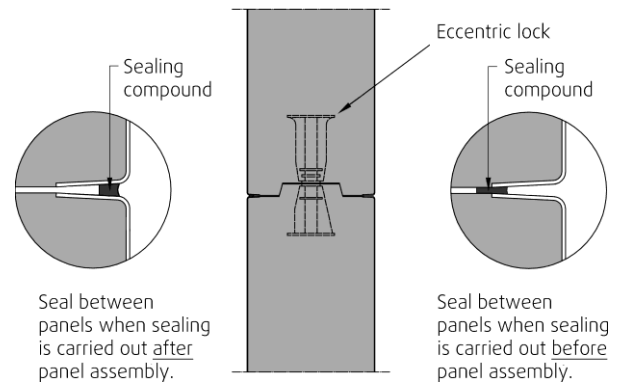

Fig. 3  
Fresvik Panel, with tongue and groove, showing panel joint in detail

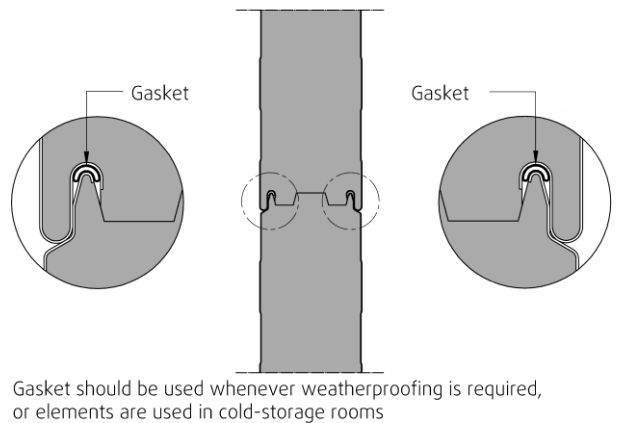

Fig. 4  
Fresvik Element

**4. Properties**

**Strength and rigidity**

Strength and rigidity of the elements shall be calculated based on the material data in table 1 and 2 at normal temperature(s).

Table 1  
Material data steel

Property	Value
Calculation for sheet thickness, exterior	0,70 mm
Calculation for sheet thickness, interior	0,55 mm
Modulus of elasticity, E steel	2,1·10 <sup>5</sup> N/mm <sup>2</sup>
Yield stress, f <sub>y</sub>	280 N/mm <sup>2</sup>
Characteristic buckling stress, for sheet thickness 0,55 mm, σ <sub>w</sub>	128 N/mm <sup>2</sup>

Table 2  
Material data polyurethane foam

Property	Value
Mod. of rigidity - calc of strength, G	2,9 N/mm <sup>2</sup>
Mod. of rigidity - calc of deformation, G	3,1 N/mm <sup>2</sup>
Modulus of elasticity, E	5,4 N/mm <sup>2</sup>
Shear strength, f <sub>v</sub>	0,12 N/mm <sup>2</sup>
Compressive strength, f <sub>c</sub>	0,22 N/mm <sup>2</sup>

**Fire resistance**

Fresvik Panel and Fresvik Element comply with class C-s3,d0 according to EN 13501-1 (with steel thickness of 0,55 mm). Fresvik Element with 13 mm plasterboard, type A according to EN 520 with density minimum 600kg/m<sup>3</sup>, between foam core and steel comply with class B-s1,d0.

**Sound insulation**

Lightweight sandwich elements generally have a limited sound-insulating capacity. If there is an indoor sound-level requirement, there may be a need for e.g. additional insulation against outdoor noise sources.

**Thermal insulation**

Declared thermal conductivity for polyurethane foam is 0.023 W/mK. Tables 3 and 4 show thermal transmittance coefficients, U-values, for finished walls of different elements, calculated in accordance with EN ISO 6946.

Table 3  
Thermal transmittance coefficients for cold-storage interior walls with Fresvik Panels

Element thickness mm	U-value, W/m <sup>2</sup> K		
	Interior wall	Interior ceiling	Interior floor with 12 mm boards
75	0.29	0.29	0.33
100	0.22	0.22	0.24
125	0.18	0.18	0.19
150	0.15	0.15	0.16
175	0.13	0.13	0.14

Table 4  
Thermal transmittance coefficients for outer walls with Fresvik Elements<sup>1)</sup>

Element thickness mm	U-value W/m <sup>2</sup> K
100	0.23
125	0.18
150	0.15
175	0.13

<sup>1)</sup> Values include additions for stainless-steel fixing screws

**Rain and air tightness**

Fresvik Elements used as exterior wall is considered to have sufficient rain and air tightness.

Testing according to EN 12153 has shown that air tightness for Fresvik Element satisfies Class 4 according to EN 12152. Testing according to EN 12865 has shown that Fresvik Element is rainproof by pressure difference 600 Pa.

**Durability**

No special tests have been carried out to determine the durability of Fresvik Panels and Fresvik Elements, but based on general experience from the use of sandwich elements with steel sheets and polyurethane foam cores, the elements are deemed to have satisfactory durability for the given fields of application.

**5. Environmental aspects**

*Substances hazardous to health and environment*

Fresvik Panel og Fresvik Element contains no hazardous substances with priority in quantities that pose any increased risk for human health and environment. Chemicals with priority include CMR, PBT or vPvB substances.

*Effect on indoor environment*

Fresvik Panel og Fresvik Element is not tested with regard to emissions to indoor air.

*Effect on soil, surface water and ground water*

The leaching properties to soil and ground water have not been tested, but based on the material composition the leaching potential is assessed to be low.

*Waste treatment/recycling*

Fresvik Panel og Fresvik Element shall be sorted as residual waste on the building/demolition site. The product shall be delivered to an authorized waste treatment plant for energy and material recovery.

*Environmental declaration*

No environmental declaration (EPD) has been worked out for Fresvik Panel og Fresvik Element.

**6. Special conditions for use and installation**

*Projecting and load-bearing capacity*

Static calculations, showing dimensioning of the elements and requisite fastening to the carrying construction, should be prepared for each individual construction. In the absence of more comprehensive dimensioning, one can use the spans as given in Table 3 for Fresvik Elements used as outer-wall elements in buildings with closed main form.

The table is valid for wind loads in accordance with NS-EN 1991-1-4, assuming form factor  $\mu = 1.0$  and elements that are freely suspended over one single span. Partial factor  $\gamma_m = 1.25$  is assumed for material properties and load factor  $\gamma_F = 1.5$  for wind load. Table 5 is calculated according to CIB Publication 257, "European Recommendations for Sandwich Panels 2000" and EN 14509 "Self-supporting sandwich elements with an insulation core and sheet-metal outer skin. Factory-made products – specifications".

Table 5  
Max. spans for Fresvik Element outer-wall elements, depending on wind loading<sup>1)</sup>

Element thickness mm	Maximum span in metres						
	Wind-speed pressure $q_{k,ast}$ in kN/m <sup>2</sup>						
	0.50	0.75	1.0	1.25	1.50	1.75	2.0
100	7.36	6.46	5.76	5.15	4.70	4.36	4.07
125	8.20	7.44	6.45	5.76	5.26	4.87	4.56
150	8.20	8.16	7.06	6.32	5.77	5.34	4.99
175	8.20	8.20	7.63	6.83	6.23	5.77	5.40

<sup>1)</sup> The spans are checked for max. deformation 1/100 of the span in serviceability limit state (SLS) with, at the same time, an applied wind load and an outside/inside temperature difference of 40 °C

Unless more accurate calculations are carried out, the supporting width should be at least 60 mm. Furthermore, the supporting width must be adapted to the fastening method and edge-spacing requirements for the fastening medium used in each individual case.

It can be assumed that 5.5 mm dia. screws and 22 mm washers have a design resistance to axial extraction of 2.2 kN at point of rupture when fastening 100 mm thick elements. The screws must then have a minimum end spacing of 25 mm and minimum edge spacing of 50 mm.

Instructions for the execution of connections to other building components, and possible reinforcements around openings, must be prepared for each individual building project.

#### *Safety in case of fire*

For the specific building project, check that the product fulfils the pre-accepted benefits in the guidelines for TEK. The product must be installed according to principles shown in SINTEF Building Research Design Guide 520.339 *Bruk av brennbar isolasjon i bygninger*.

#### *Installation of Fresvik Panels in cold-storage rooms, etc.*

The element joints must be sealed on both sides with an accompanying silicone-based sealing compound as shown in Fig. 2 and Fig. 3. Sealing compound is also used for sealing connections at floor, ceiling, etc. If one cannot gain access from both sides after assembly, sealant must be applied between the elements prior to assembly. Before applying sealing compound, all joint surfaces must be degreased and cleaned in accordance with the sealant supplier's instructions. The apertures for the eccentric locks must be plugged after assembly.

Moreover, construction details for the elements must be executed as given in "*Standard Construction Details for Fresvik Panels and Fresvik Elements pertaining to SINTEF Technical Approval TG 2135*".

It is presupposed that cold-storage rooms with Fresvik Panels are equipped with a pressure-equalising valve.

#### *Installation of Fresvik Elements in exterior walls*

Wall elements may be installed vertically or horizontally. Vertical elements should be installed as full wall height, without any horizontal joints. The elements must be attached to the building's load-bearing system in accordance with instructions based on static calculations for the building in question.

The elements are to be fastened to each end support using at least two screws located min. 25 mm from the end of the element, and preferably 100 mm (but at least 50 mm) from longitudinal element joints. Vertical elements are to be fastened in the same manner as horizontal elements.

Penetrating fastening screws must be of stainless steel and have washers with neoprene seals, or similar. Other fastening media and fittings/hardware must have satisfactory corrosion protection.

All element joints must be sealed with sealing compound and/or sealing foam as given in "*Standard Construction Details*" and covered by a drained rain shield in the form of flashing in order to achieve two-stage tightening. The joint width should be max. 50 mm and min. 10 mm.

When installing windows and doors the weatherboard/ windowsill flashing must have 20-30 mm high gables with watertight corners. Side flashings must extend beyond flashing gables and finish approx. 10 mm beyond the windowsill flashing in question.

In the case of PVC and aluminium windows, a tightening and installation technique other than that given in "*Standard Construction Details*" must be chosen, because sealing foam does not provide sufficient adhesion/grip.

All flashings should be fastened using screws with neoprene washers or similar. Parapet flashings must be folded at the corners.

#### *Installation in general*

Shears/tin snips must be employed when cutting elements or steel sheets on site.

Every delivery is accompanied by delivery documents that (minimum) include the manufacturer's name and address, project ID, material specification for the individual consignment and design/construction details that (minimum) include production drawings, and (possibly) details from "*Standard Construction Details*".

#### *Protection*

In buildings subject to excessive water spillage, etc., floor transitions must be formed so that the elements do not stand in puddles of water.

In buildings where wheeled transport can reach the walls, the elements should be protected against mechanical damage with the aid of concrete plinths, rails, or similar.

#### *Maintenance*

Solvents must not be used when cleaning the elements. Joints should be regularly inspected to ensure that the sealing compound has sufficient adhesion/grip. Scratches in the surface should be rectified using paint/ lacquer.

#### *Transport and storage*

Fresvik Panels/Elements should be delivered to the building site protected by plastic packaging. The elements must be stored on a level, flat base, and should be shielded from rain and direct sunlight. The elements must be protected against mechanical damage caused by striking, jolting and bumping during transport and storage.

### **7. Factory production control**

Fresvik Panels and Fresvik Elements is produced by Fresvik Produkt AS, Fresvikvegen 995, NO-6896 Fresvik.

The holder of the approval is responsible for the factory production control in order to ensure that Fresvik Panels and Fresvik Elements is produced in accordance with the preconditions applying to this approval.

The manufacturing of Fresvik Panels and Fresvik Elements is subject to continuous surveillance of the factory production control in accordance with the contract regarding SINTEF Technical Approval.

### **8. Basis for the approval**

The evaluation of Fresvik Panels and Fresvik Elements is based on reports owned by the holder of the approval.

The evaluation of design and technical solutions are based on recommendations given in SINTEF Building Research Design Guides.

**9. Marking**

Each element must be marked with an internal production code. Every consignment must be accompanied by documents as stipulated in Item 7.

The approval mark for SINTEF Technical Approval No. 2135 may also be used.

**10. Liability**

The holder/manufacturer has sole product responsibility according to existing law. Claims resulting from the use of the product cannot be brought against SINTEF beyond the provisions of Norwegian Standard NS 8402

for SINTEF



Hans Boye Skogstad  
Approval Manager