

SINTEF confirms that

Isola Mestertekk single layer bituminous roofing membrane

has been found to be fit for use in Norway and to meet the provisions regarding product documentation given in the regulation relating to the marketing of products for construction works (DOK) and regulations on technical requirements for building works (TEK), with the properties, fields of application and conditions for use as stated in this document

1. Holder of the approval

Isola as
 NO-3945 Porsgrunn
www.isola.no

2. Product description

Isola Mestertekk is a single layer bituminous roofing membrane, with a reinforcement of spunbond polyester laminated with aluminium foil. The reinforcement is impregnated with bitumen and coated with SBS modified bitumen on both sides. The Isola Mestertekk has a surface protection of granules. The underside is covered with a plastic film, which melts during welding. Isola Mestertekk is available in several different surface colours.

Measures and tolerances are stated in table 1.

Table 1
 Dimensions and tolerances for Isola Mestertekk according to EN 1848-1 and EN 1849-1

Property	Value
Thickness	3.9 mm
Weight	4.6 kg/m ² ± 0.3 kg/m ²
Width	1 m ± 2 mm
Roll length	8 m +100 mm / -0 mm
Weight of reinforcement	Ca. 250 g/m ²

3. Fields of application

Isola Mestertekk roofing membrane is used as a single layer membrane for sloped and flat roofs. The system is designed for use as a mechanically fixed single layer roofing membrane.

Roofs must have adequate slope to drain water from rain and melted snow. SINTEF recommends in general a minimum slope of 1:40 for all roofs.

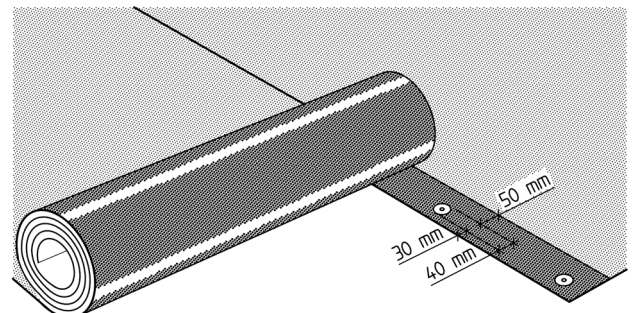

Fig. 1
 Isola Mestertekk
 Mechanical fastening in welded side overlap

4. Properties

Material properties

Product characteristics for fresh material are shown in table 2.

Properties related to fire

Isola Mestertekk has a reaction to fire classification B_{ROOF} (t2) according to EN 13501-5 on substrates shown in table 3. Testing is performed according to CEN/TS 1187-2.

Durability

Isola Mestertekk has shown satisfactory properties after artificial ageing in connection with type-testing, and audit testing, performed by SINTEF.

Fastener capacity

The design capacities, at ultimate limit state, for tested fasteners are given in table 4. The capacity applies to the connection between the membrane and the fastener and is determined in form of a system test.

For weak substrates, the connection between the substrate and the fastener might limit the capacity. This must be considered, and only the lowest capacity for membrane, or substrate underlays, must be used.

Table 2

Product characteristics for fresh material of Isola Mestertekk single layer bituminous roofing membrane

Property	Test method EN	DoP ¹⁾	Control limit ²⁾	SINTEF's recommended minimum performance ³⁾	Unit
Dimensional stability (L/T)	1107-1	--	≤ ±0.5	≤ ±0.6	%
Flexibility at low temperature Top side out/ Underside out	1109-1	≤ -20	≤ -20	≤ -15	°C
Flow resistance at elevated temperature	1110 ⁴⁾	-	≥ 90	≥ 90	°C
Water tightness 10 kPa/24 h	1928 (A)	Watertight	Watertight	Watertight	-
Adhesion of granules ³⁾	12039	≤ 1,0	≤ 1,0	≤ 2.5	g
Resistance to tearing, nail shank	L T 12310-1	300 ±25 % 320 ±20 %	≥ 225 ≥ 255	≥ 150	N
Tensile strength	L T 12311-1	1000 ±20 % 800 ±20 %	≥ 800 ≥ 640	≥ 600	N/50 mm
Elongation	L T 12311-1	45 ±20 % 50 ±20 %	≥ 35 ≥ 40	≥ 10	%
Maximum peel resistance of joints	12316-1	-	≥ 210 ⁵⁾	-	N/50 mm
Average peel resistance of joints	12316-1	210 ± 20 %	≥ 165	≥ 50	
Shear resistance of joints	12317-1	750 ± 20 %	≥ 600	≥ 600	N/50 mm
Resistance to puncturing Impact +23 °C	12691 (A)	≥ 800	≥ 800	≥ 500	mm
Impact -10 °C	12691:2001	-	≤ 30	≤ 30	mm diam
Static load	12730 (A)	≥ 20	≥ 20	≥ 20	kg
Watertightness after stretching at low temp. (10% elongation at -10 °C)	13897	-	Tight	Tight	-

¹⁾ Declared values in the performed statement of the producer (Declaration of Performance. DoP).

²⁾ The stated values are control limits existing for internal control at the producer and by supervising control.

The control limits are consistent with the lowest range of variation for the manufacturer's declared value in DoP

³⁾ SINTEF's recommended minimum performance in SINTEF Technical Approval for single layer bituminous waterproofing membrane

⁴⁾ Modified to only give the result of weight loss of granules in gram.

⁵⁾ Value based on result from type testing

L = Longitudinal

T = Transversal

Table 3

Isola Mestertekk achieves reaction-to-fire classification B_{ROOF} (t2) on the following substrates

Type of sub construction	Mestertekk
EPS ¹⁾	Yes
Rockwool	Yes
Wooden sheeting	Yes
Concrete	Yes
Reroofing on old membrane on EPS ¹⁾	Yes
Reroofing on old membrane on stone wool	Yes
Reroofing on old membrane on wooden	Yes
Reroofing on old membrane on concrete	Yes

¹⁾ In case of roofing on lightweight combustible insulation (e.g EPS, XPS or PIR), see section 6 *Special Conditions for use*, section *Substrate*, regarding requirements for replacement of flammable insulation to non-combustible insulation around bushings and against adjacent structures.

Table 4

Design capacity at ultimate limit state for fastening of Isola Mestertekk single layer roofing membrane

Type of fastener, fixed in 120 mm welded overlap	Design capacity N / fastener
Clout nails 2.8 – 25	190
Ecotek 45 washer	900
SFS Iso-tak R45/RP45	900 ¹⁾
SK Tuote Oy KLA-roof screw, NO-1 TX SK Tuote Oy Croco B washer	980 ²⁾

¹⁾ The stated capacity apply to Norwegian conditions and include a safety factor $\gamma_m = 1.3$

²⁾ Measured according to EN 16002 with the safety factor used in Norway $\gamma_m = 1.3$.

The number of fixing points are calculated according to SINTEF Building Research Design Guide 544.206 *Mekanisk feste av asfalt takbelegg og takfolie på flate tak* and "TPF informerer nr. 5" issued by Takprodusentenes Forskningsgruppe, see www.tpf-info.org.

5. Environmental aspects

Substances hazardous to health and environment

Isola Mestertekk contains no hazardous substances with priority in quantities that pose any increased risk for human health and environment. Chemicals with priority include CMR, PBT or vPvB substances.

Effect on soil, surface water and ground water

The leaching properties of the Isola Mestertekk are evaluated to have no negative effects on soil or water.

Waste treatment/recycling

Isola Mestertekk shall be sorted as residual waste. Isola Mestertekk shall be delivered to an authorized waste treatment plant for energy recovery.

Environmental declaration

No environmental declaration (EPD) has been worked out for Isola Mestertekk.

6. Special conditions for use and installation

Installation

The roofing membrane shall be fixed mechanically in a 120 mm wide welded side overlap, see fig. 1. The position of the fasteners is indicated by a marking line 50 mm from the edge of the sheet. This will normally give 30 mm of bonding on the inside of the washer and 50 mm on the outside. Bonding on the inside of the washers must be minimum 25 mm, and minimum 45 mm on the outer side.

End overlaps shall be 150 mm. The lower corner shall be fixed, and the overlapping corner shall be cut at a 45° angle. A good result depends on "drowning" the surface granules of the underlying membrane before welding the two sheets.

Incidentally, the roofing membrane shall be installed in accordance with the vendor's installation manual and the principles shown in SINTEF Building Research Design Guides 544.203 *Asfalttakbelegg. Egenskaper og tekking*, 544.204 *Tekking med asfalttakbelegg eller takfolie. Detaljløsninger* and 544.206 *Mekanisk feste av asfalttakbelegg og takfolie på flate tak*, and "TPF informerer nr. 5" published by Takprodusentenes Forskningsgruppe.

Fasteners

Standard steel washers may be used in longitudinal overlapping joints on firm substrates such as wood-based roof sheathing or concrete.

On substrates of thermal insulation, with compressive strength ≥ 80 kPa (level CS(10)80, according to EN 13162/13163), steel washers with deep collars or plastic washers should be used.

Washers with integrated sleeves and good telescopic function must be used for installation on thermal insulation with lower compression strength. Tightening of the fasteners must be checked particularly.

Substrate

When a fire classification is required the substrate must be in accordance with the provisions stated in table 3.

Substrate of combustible insulation as EPS, XPS or PIR must be covered (or split up) and also replaced with non-combustible insulation around bushings and adjacent constructions. See regulations in "Veiledning om tekniske krav til byggverk" § 11-9 and further description in "TPF informerer nr. 6" *Branntekniske konstruksjoner for tak* published by Takprodusentenes Forskningsgruppe.

Traffic on the roof

Special precautions must be taken to protect the roofing membrane when the roof is expected to have more traffic than is necessary for inspection and maintenance purposes.

Cleaning and maintenance

Before starting any welding, as a part of repair work, the roofing membrane must be cleaned locally, in accordance with the manufacturer's guidelines.

Storage

Isola Mestertekk must be stored in upright position on pallets.

7. Factory production control

Isola Mestertekk is produced by Isola as, 3945 Porsgrunn, Norway.

The holder of the approval is responsible for the factory production control in order to ensure that the Isola Mestertekk is produced in accordance with the preconditions applying to this approval.

The manufacturing of the Isola Mestertekk is subject to continuous surveillance of the factory production control in accordance with the contract regarding SINTEF Technical Approval.

Isola as has a quality management system certified in compliance with EN ISO 9001:2015.

8. Basis for the approval

Product properties have been verified by tests carried out at SINTEF and documented in annual control reports, and type testing documented in the following reports:

- O 3741A, dated 03.12.1992, Material properties
- O 14343, dated 04.05.2004, Material properties
- Report SINTEF Byggforsk; SBF 2016 F0563, dated 2016-11-21, adhesion of granules
- SP, report 6P09357 dated 2016-11-28, fire testing (EPS)
- SGS Intron, report A106500/R20190349 dated 2019-09-26, leaching test
- SINTEF report 2020:01337, dated 2020-12-16, tear- and tensile resistance

Data for fastening of the roofing membrane (shown in table 4) are based on system tests according to NT Build 307 and EN 16002, supplemented by comparable results from simplified testing according to test method NBI 163/91, cf. report O 3741B dated 09.12.1992 from the Norwegian Building Research Institute and report 20151129-89 dated 02.12.2015 from Construtech.

9. Marking

Each roll is marked with the manufacturer's name, product description and production date.

Isola Mestertekk is CE marked in accordance with EN 13707.

The approval mark for SINTEF Technical Approval No. 2022 may also be used.



Approval mark

10. Liability

The holder/manufacturer has sole product responsibility according to existing law. Claims resulting from the use of the product cannot be brought against SINTEF beyond the provisions of Norwegian Standard NS 8402

for SINTEF



Hans Boye Skogstad
Approval Manager